

# WindWise Education

*Transforming the Energy of Wind into Powerful Minds*

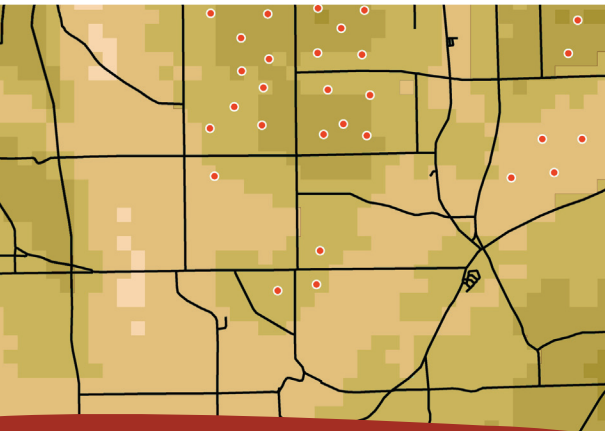
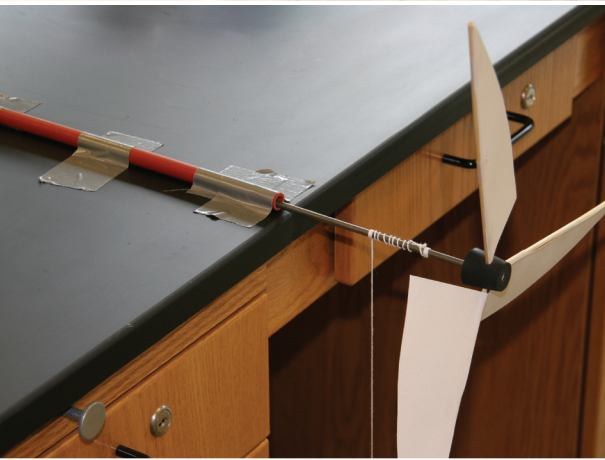

## A Curriculum for Grades 6–12

### Notice

Except for educational use by an individual teacher in a classroom setting this work may not be reproduced or distributed by mechanical or by electronic means without written permission from KidWind or Normandeau. For permission to copy portions or all of this material for other purposes, such as for inclusion in other documents, please contact Michael Arquin at the KidWind Project at [michael@kidwind.org](mailto:michael@kidwind.org)



2<sup>nd</sup>  
edition



[www.WindWiseEducation.org](http://www.WindWiseEducation.org)



WindWise Education was developed with funding from the New York State Energy Research & Development Authority



Updates to Lessons 3 & 5 and the addition of Lesson 16 were funded by the Department of Energy: subcontract No.AFT-I-40657-01

# HOW DOES A WINDMILL WORK?

LESSON

8

## KEY CONCEPT

Students learn the fundamental parts of a windmill, how different rotor designs affect performance, and how energy is transferred from wind into usable mechanical energy.

## TIME REQUIRED

2 class periods

## GRADES

6–8  
9–12

## SUBJECTS

Physical Science  
Technology/Engineering

## BACKGROUND

Windmills are the ancient ancestors of modern wind turbines. To understand how wind turbines work, one must first understand a basic windmill. This lesson will help students understand how a windmill captures the energy of the wind and converts it into usable mechanical energy, which is the basis for understanding modern wind turbines. Students will use the engineering design process and the scientific method to design, build, test, and improve their models.

## OBJECTIVES

At the end of the lesson, students will:

- know the fundamental parts of a windmill
- be able to use the scientific method to isolate and adjust variables in a model windmill
- understand energy conversions/transfers and how a windmill converts moving air into usable mechanical energy

## METHOD

Students will use a limited amount of materials to design and build functioning windmill models. They will use these models to convert wind into usable mechanical energy to lift weights. Using the scientific method, they will conduct trials, change variables, and work to improve the performance of their windmills.

## MATERIALS

Each group needs

- 1 small electric fan
- 1 3/8" Wooden Dowel 16"
- 1 piece of 1/2" PVC pipe (10" long)
- 4–8 index cards (4" x 6")
- 4 wooden shish kebab skewers (10" long)
- 4 feet of string
- 1 12-ounce paper deli cup
- 1 16-ounce plastic cup
- 1 foam cylinder
- 1 cork
- 4 straight pins or T-pins
- Clear Scotch Tape (18")
- 1 pair of scissors
- 15 steel washers
- Student Worksheets

Classroom materials to share

- Staplers
- Various simple tools (pliers, screwdriver, etc.)

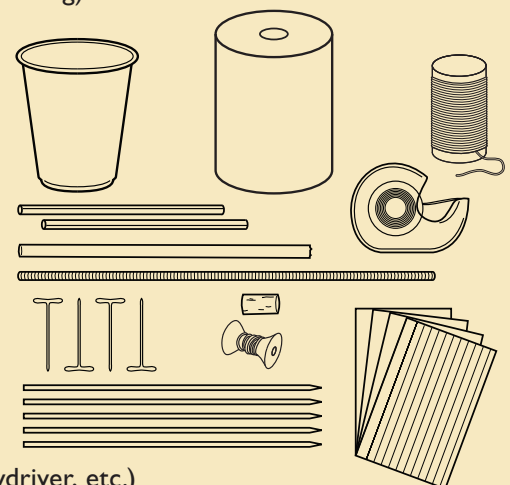

### CAUTION!

- Do not stand in the plane of rotation of the rotor! (See diagram below.) You could be hit if your blade flies off during testing.
- The spinning rotor blades and metal rod can be dangerous. Make sure students work with caution.
- Be careful when working with the metal rod. Do not swing or play with the rod! The ends can be protected with tape, foam, cork, etc.
- Wear safety glasses when testing windmills. Safety glasses must be worn any time blades are spinning.

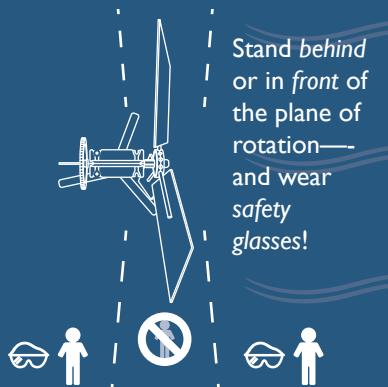

### GETTING READY

- It is strongly suggested that teachers try to build their own windmills before the class begins. This is a valuable preview to the challenges and problems that students will face.
- Separate the materials to distribute to each group. Remember that materials for this activity are intentionally limited, as this encourages creativity and discourages waste. Use small, weak fans (8 inch diameter) to encourage the students to build efficient designs.
- Ask students to do some background reading on windmills and wind power.
- The “Additional Resources” section below offers a great deal of background information. Students should have read the Career Profile before class period 2.
- Make copies of the worksheets for each student group.

### ACTIVITY

In the first class period, students should focus on getting their prototypes to spin when placed in front of the fan. In the second class period, students will work to get the windmill to lift a cup of weights (washers) as it rotates.

#### *Class Period 1*

#### **Step 1: Beginning questions for students**

- Who has seen a real windmill (mechanical or electrical)?
- What are the parts and features of a windmill?
- What are windmills used for?
- How does the wind cause the windmill to rotate?

#### **Step 2: What is a windmill?**

Ask a couple of students to draw a windmill on the blackboard. Ask the other students to describe how these windmills work and what they are used for.

#### **Step 3: Distribute materials**

Present the windmill design activity to the students and organize them into groups of 3–5. Give each group the required materials. (Do not pass out the string, cups, or washers yet, as these will be distributed at the beginning of the second class period when the weight-lifting challenge is presented.) As you distribute the materials, be sure to mention some ground rules for safety. (See note in margin, on left.)

#### **Step 4: Spin in the wind**

Instruct the students to assemble a mechanism that will rotate when placed in the wind. Tell them not to worry about lifting weight yet. The first challenge is just to get the windmill to spin. (Note: there are not enough materials to build a tower. These windmills should be held by hand or attached to the desktop.)

**Step 5: Design and testing**

Give the groups plenty of time for initial designing and construction. Each group should have a chance to test its windmill with the fan at least once during this first class period. There is no right answer here and many designs are possible. Students will feel confused. That is okay!

**Step 6: Wrap up**

At the end of class, show the students different pictures of real windmills and wind turbines. Discuss how windmills work and the fundamental parts of a windmill. How do these real windmills differ from their initial designs? What new ideas do the pictures give them?

Other possible questions

- What windmill designs worked best?
- What parts were most difficult to design and make functional?
- How did you attach your blades?
- Where is there *friction* in your design?
- How did you reduce friction in your windmill?
- How did you pitch or angle the blades?
- Were your blades changing pitch frequently?
- Did the fan work better from the front of the blades or the side?
- What energy transfers were taking place as the windmill spun?

*Class Period 2*

**Step 1: Weight-lifting challenge**

By the beginning of this class period, most groups should have gotten their windmills to spin in the wind. Now introduce the weight-lifting challenge. Give each group the string, cups, and washers. Their goal is to use the power of the wind to lift as many washers as possible. As students work toward this goal, they will have to isolate and improve certain variables in their designs.

**Step 2: Testing variables and improving designs**

As students test their weight-lifting windmills, give them guidance and tips on how to improve their designs. Encourage them to focus on one variable at a time; conduct a trial, measure the results, make changes, and repeat the trial. The size, shape, pitch (angle), and number of blades can be explored. The variables of fan setting (speed) and distance from the windmill should be kept constant. Encourage students to use the scientific method as they design and test their prototypes.

Some groups may struggle to get the windmill to lift any weight. Encourage them to look at other groups that have been successful. What techniques work well and what does not seem to work? Remind students that this activity is not a competitive contest, but rather a class effort. Students can learn from and support each other.

**BLADE PITCH**

Blade pitch is the angle of the blades with respect to the plane of rotation. The pitch of the blades dramatically affects the torque of the rotor. Pitch also affects the amount of drag experienced by the blades. Efficient blades will provide maximum torque with minimum drag.

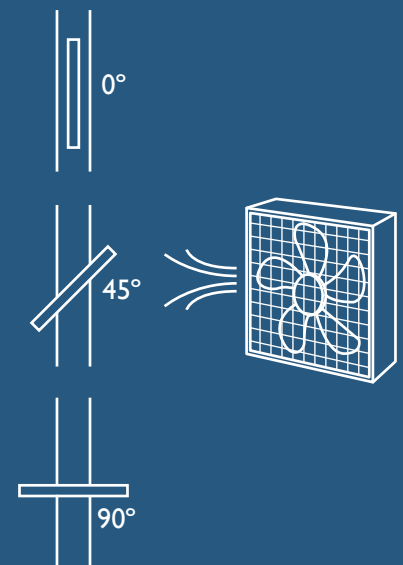

## HOW DOES A WINDMILL WORK?

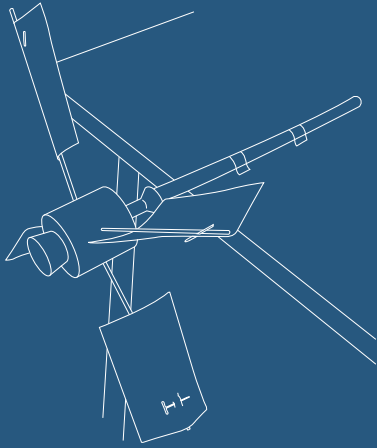

Tell students to hold their windmills or tape them to a desk.

### Step 3: Wrap up

- How many blades worked well for lifting weight?
- Did more blades mean you could lift more weight?
- What **blade pitch** was best for lifting weight?
- Where did you attach the string? Why?
- How did your design change after the attempt to lift weight?
- How were you able to get more turning **force** from your blades?
- What energy transfers took place as weight was lifted?
- What ideas seemed to work well?
- What problems did you encounter?
- What skills did you use that Pat Walsh (Career Profile) also uses as a wind turbine technician?
- What parts of your windmill broke or failed? Are those the same parts that Pat Walsh fixes on turbines?

### EXTENSION

For a quantitative analysis of different **rotor** efficiencies, tell students to calculate the energy required to lift the mass they have lifted and the power of their windmill as it lifts that mass. Energy is measured in joules (J). Power is measured in watts (W). Power is a measurement of how fast energy is converted. In this case, power is a measurement of how fast the mass is lifted.

To calculate how much energy is required to lift the washers, students will first need to measure the mass (kilograms) of the washers they are lifting and how high they are lifting the washers (meters).

$$\text{Energy (J)} = \text{Mass (kg)} \times \text{Acceleration of Gravity (9.8 m/s}^2\text{)} \times \text{Height (m)}$$

To measure power, they must also measure how long it takes to lift the mass to that height (seconds). Standardize the height so that every group must lift to the same height (0.5 meter or so).

$$\text{Power (W)} = \text{Energy (J)} / \text{Time (s)}$$

Tell students to record their data on the Power and Energy worksheet. Recording these data and calculating power for different prototypes will give the students a quantitative comparison.

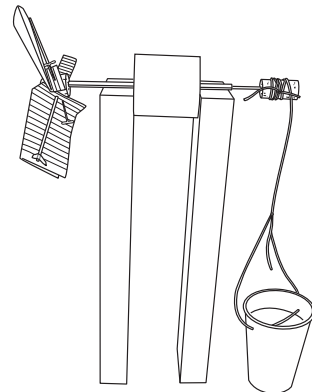
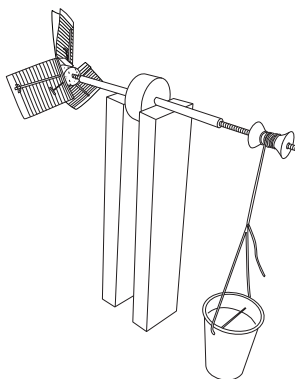

## VOCABULARY

**blade pitch** – The angle of the blades with respect to the plane of rotation. (Blades perpendicular to the oncoming wind would be 0 degrees. Blades parallel to the wind would be 90 degrees.)

**drag** – In a wind turbine, this is also called wind resistance. The friction of the blades against air molecules as they rotate. Drag works against the rotation of the blades, causing them to slow down.

**driveshaft** – The rod or shaft connected to the hub; it rotates with the rotor.

**energy transformation** – The conversion of energy from one form to another. For example, when coal (chemical energy) is burned, it produces heat (thermal energy) that is then captured and used to turn a generator (mechanical energy), which transforms the energy into electricity (electrical energy).

**force** – A push or pull.

**friction** – A force that resists the relative motion of two bodies in contact.

**hub** – Central component connecting the blades to the driveshaft.

**plane of rotation** – The area directly in line with the rotor. This is a dangerous area to stand in case a blade flies out while the windmill is spinning.

**rotor** – The rotating section comprised of blades projecting from a hub.

**torque** – A force times a distance that causes rotation. In a windmill, each blade acts like a lever arm rotating around an axis. The more surface area the blade has, the more torque the wind applies to the blade.

## RELATED ACTIVITIES

- Lesson 9: How Does a Generator Work?
- Lesson 10: Which Blades Are Best?
- Lesson 11: How Can I Design Better Blades?

## ADDITIONAL RESOURCES

DPBS Kids ZOOM!—<http://kwind.me/v7c>—Windmills activity.

KIDWIND PROJECT—<http://kwind.me/v6c>—PowerPoint of wind power basics.

THE WIND AT WORK—Book by Gretchen Woelfe.

WHEELS AT WORK—Book by Bernie Zubrowski.

WIND WITH MILLER— <http://kwind.me/b8n> —This is a good introduction to wind energy and wind turbines. Great for grades 6–8.

## HOW DO BLADES MOVE?

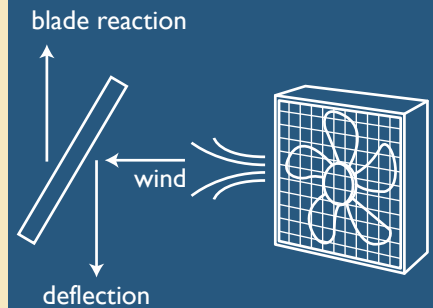





### **CAREER PROFILE: PAT WALSH, WIND TURBINE TECHNICIAN**

A wind turbine technician repairs and maintains wind turbines. That means that every day I get to climb 300-foot towers and fix broken turbines! To be able to repair a wind turbine, I had to become an expert in hydraulics, electricity, wind turbine mechanical systems, and electronics. Technicians must also be physically fit and very safety conscious, as the job can be physically strenuous. Of course, I cannot be afraid of heights, either. While the heights may sound scary, the perks of this job are good. I earn a competitive salary with benefits, not to mention enjoying the spectacular views every day while on the job! In addition, I, like many technicians, got to travel to Europe as part of my training.

Colleges across the United States have begun offering training programs for wind turbine technicians. These 2-year programs teach students everything they need to know to be a certified “wind-smith.” I was trained at Iowa Lakes Community College, but my co-workers came from several different schools. These days, demand for wind technicians is high, and some students are hired by the wind industry while they are still finishing their training.



Name \_\_\_\_\_ Date \_\_\_\_\_ Class \_\_\_\_\_ Group \_\_\_\_\_

**HOW DOES A WINDMILL WORK?**

1. Draw a diagram of your windmill design in the space below. Label the following parts: blades, rotor, hub, driveshaft. Label these concepts: force, friction, distance (height of string).

2. Which of the following variables did you explore?  
Number of blades, blade shape, blade size, blade pitch (angle), fan location, wind speed, other (explain).

3. Rank the variables in your design from most important to least important.





Name \_\_\_\_\_ Date \_\_\_\_\_ Class \_\_\_\_\_ Group \_\_\_\_\_

**EXTENSION ACTIVITY**

<b>WINDMILL DESIGN</b>	<b>MASS (KG)</b>	<b>DISTANCE (M)</b>	<b>TIME (S)</b>	<b>ENERGY (J)</b>	<b>POWER (W)</b>
example	0.1	1	10	0.98	0.098

1. Which design had the most power? Why?

2. How is your windmill different from windmills you have seen in real life or pictures?

3. Did you notice any relationship between the size of your blades and the power output?

1. Draw a diagram of your windmill design below. Label the following parts: blades, rotor, hub, drive shaft. Label these concepts: force, friction, distance (height of string).

*There will be friction wherever the driveshaft rubs against something else. In this case, the driveshaft rubs on a piece of tubing it is going through.*

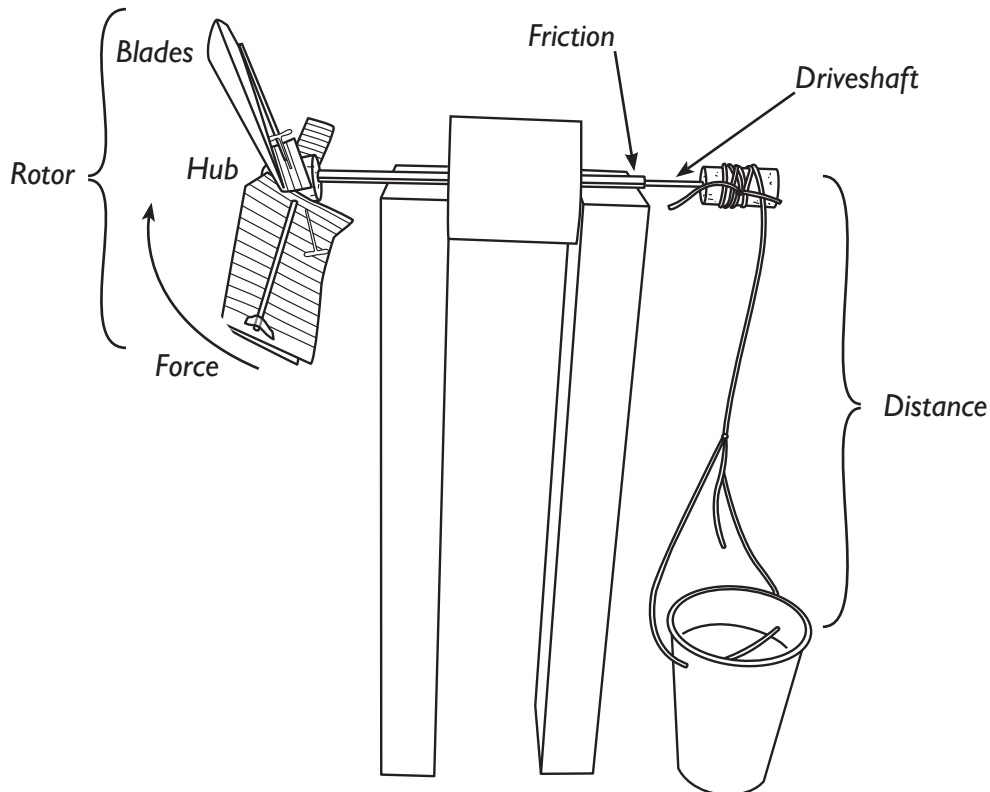

2. Which of the following variables did you explore?  
*Student observations.*
3. Rank the variables in your design from most important to least important.  
*Answers will vary. Wind speed and blade pitch are very important variables.*
4. What effect did the number of blades have on how much weight your windmill could lift?  
*More blades will give the windmill more torque, which usually allows it to lift more weight. Typically 6 blades can lift more than 3 blades.*
5. How did the pitch (angle) of the blades affect the amount of weight your windmill could lift?  
*Blade pitch is a very important variable. Shallow pitched (10–30 degrees) blades can spin faster, but more pitch (30–60 degrees) can give the windmill more torque. Typically students find that blades pitched at 30–45 degrees lift the most weight.*

6. Draw a picture of your wind turbine and label the energy transfers or conversions that took place as you used the wind to lift weight.

Energy Transfers/Conversions:

Wind Energy → Mechanical/Rotational Energy → Potential Energy (elevated mass)

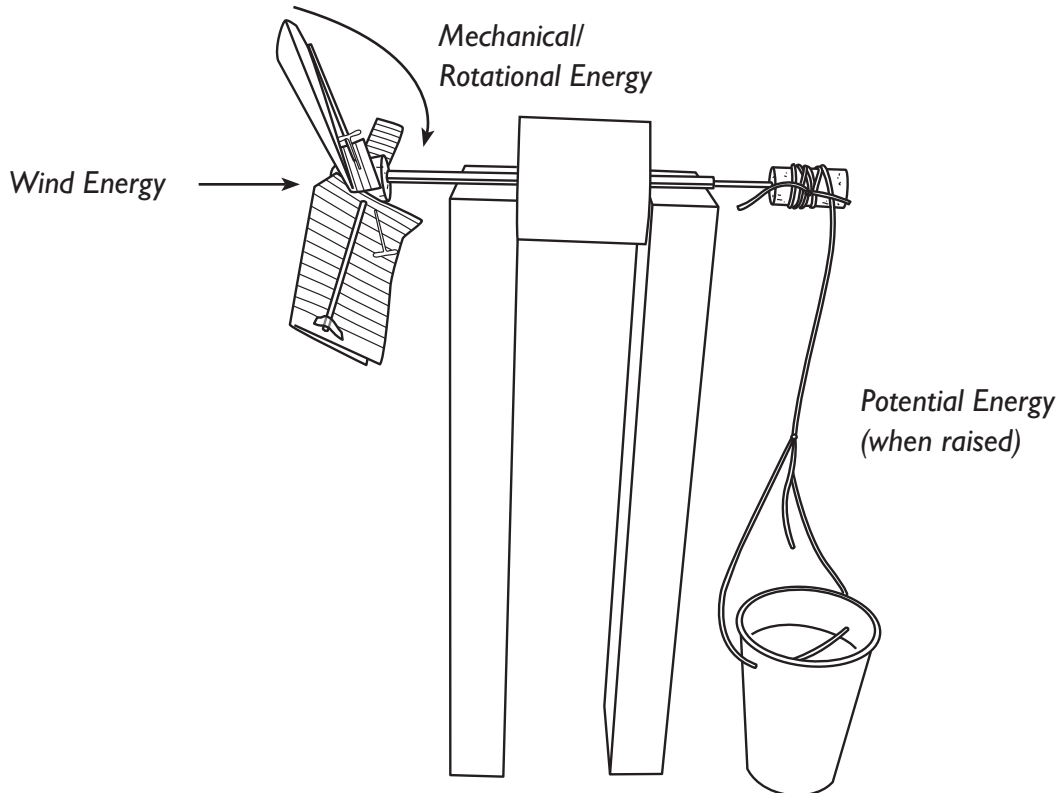

7. Explain the windmill design that had the best results. Why do you think this design worked best?  
*Answers will vary. The best windmills will be well constructed with sturdy blades and a bearing system that minimizes friction. They will most likely have 3–6 blades pitched at 30–45 degrees.*